

APPROVAL

DATE

SIGNATURE

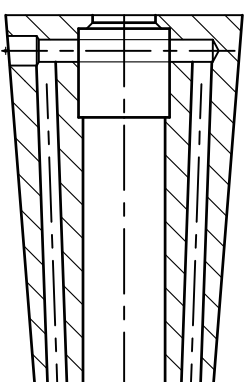

- NOTE
- 1.ROUND R=10
 - 2.BREAK SHARP CORNERS 0.5x45°
 - 3.ANGLES ±0°15'
 - 4.SFH-C ADJUST BOLT(T) : M10x1.0x15L
 - 5.NYLOC BOLT : M4x0.7x4L(4EA)
 - 6.BALANCE : G2.5 / 25,000rpm

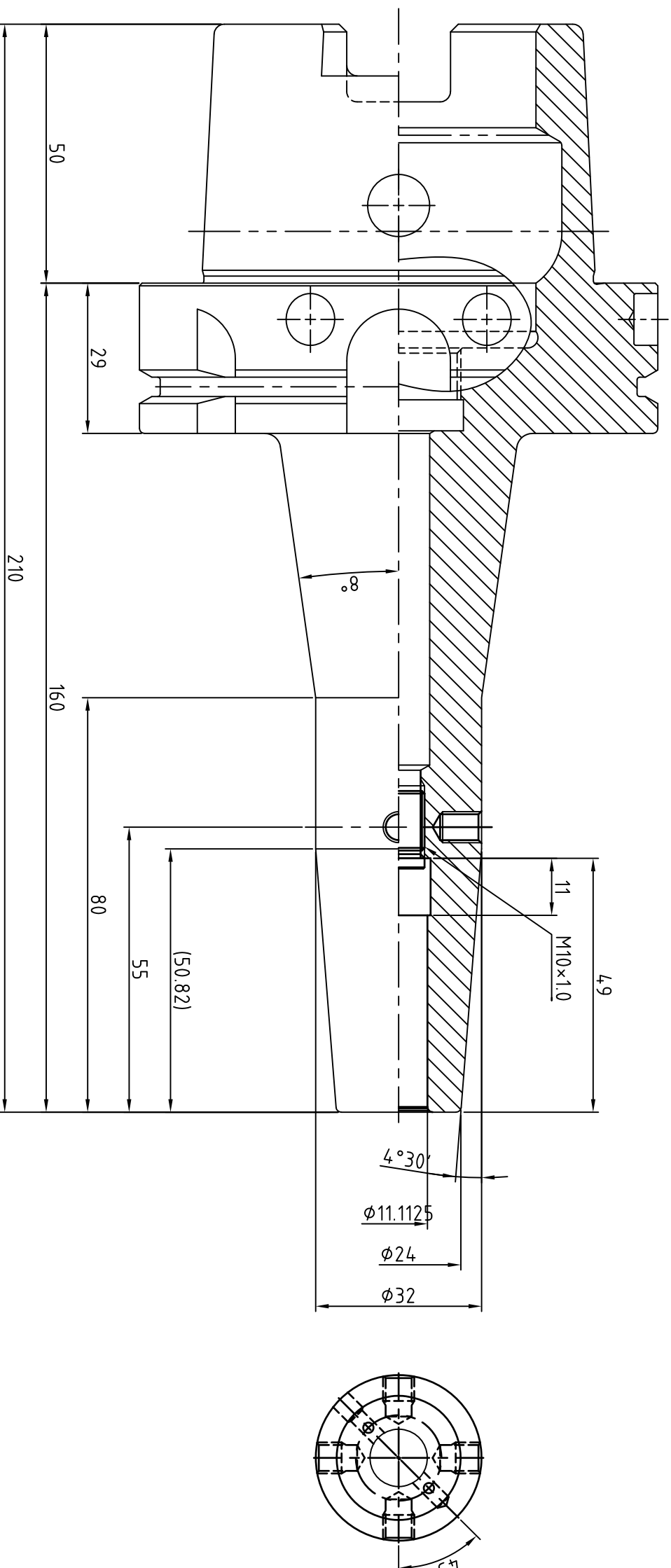

MARKING	
	HSK100A-SFH7/16CTW-6.30
	VR064JTW 월/년0일 G2.5/25,000

MATERIAL	REV No.	00	DATE	2021.03.22	표	기	호	Rmax	Ra	Rz	기	본	구	1-50	50-100	100-250	250-500	DRAWN	CHECKED	CHECKED	CHECKED	APPROVED
MAT. SIZE	SURFACE TREATMENT				면	~	▽	-	-	-	차	분	내	+0.1	+0.15	+0.25	+0.35	Y.H.J				
HARDNESS	KIND	HR C	ASME B5.50	2009	조	▽	▽	100S	25a	100Z	경	경	외	-0.1	+0.15	-0.25	-0.35					
DESCRIPTION	SHRINK FIT HOLDER		OEM CODE	VR064JTW	도	▽▽	▽	25S	63a	25Z	정	정	전	±0.1	±0.15	±0.25	±0.35					
ORDER MAKER	SAB					▽▽▽	▽	6.3S	1.6a	6.3Z	SCALE	SCALE	1 : 1									
SPEC.	HSK100A-SFH11.1125(7/16")CTW-160(6.30")		TYPE	Machining		▽▽▽▽	▽	0.8S	0.2a	0.8Z	Dim.	mm										