

APPROVAL

DATE

SIGNATURE

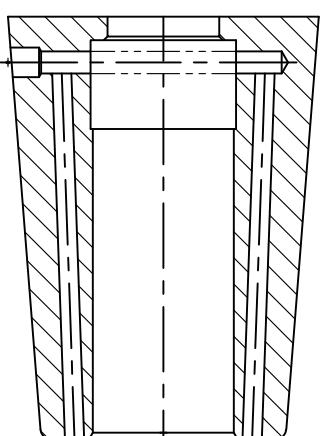

- NOTE
- 1.ROUND R=1.0
 - 2.BREAK SHARP CORNERS 0.5x45°
 - 3.ANGLES ±0°15'
 - 4.SFH-C ADJUST BOLT(T) : M12x1.0x15L
 - 5.NYLOC BOLT : M4x0.7x4L(4EA)
 - 6.BALANCE : G2.5 / 25,000rpm

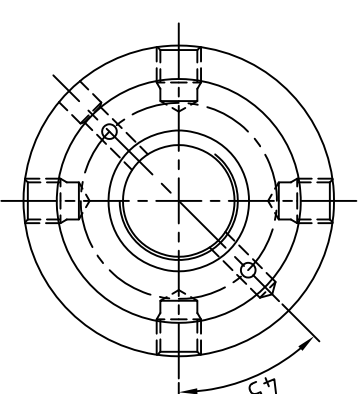
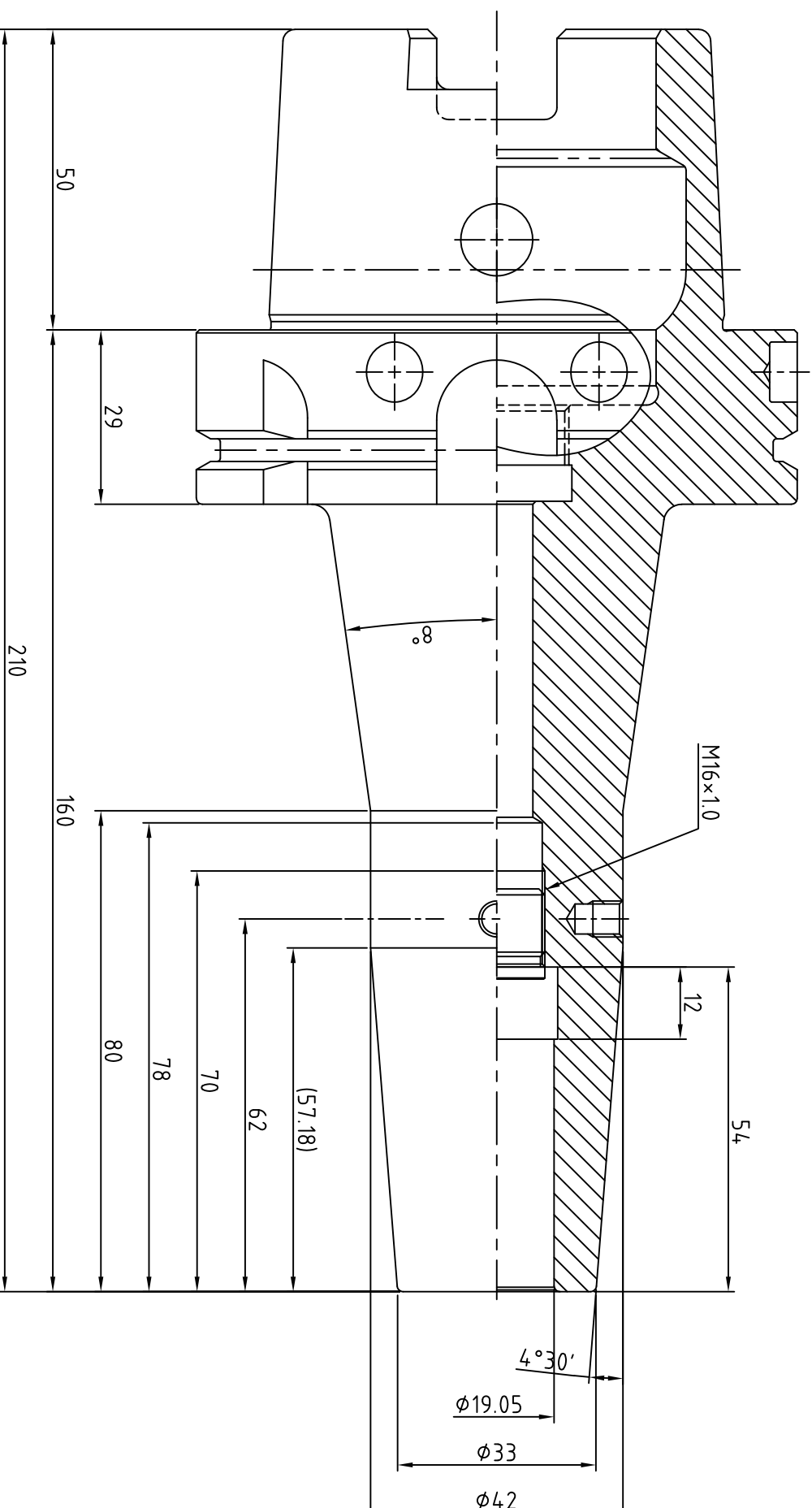

MARKING	
	HSK100A-SFH3/4CTW-6.30
	VR038JTW 월/년 0일 G2.5/25,000

MATERIAL	REV No.	00	DATE	2021.03.22
MAT. SIZE	SURFACE TREATMENT			
HARDNESS	H _R C	KIND	ASME B5.50 : 2009	
DESCRIPTION	SHRINK FIT HOLDER			
ORDER MAKER	SAB	OEM CODE	VR038JTW	
SPEC.	HSK100A-SFH19.05(3/4")CTW-160(6.30")			
		TYPE	Machining	

표면	기호	R _{max}	R _a	R _z	기분공차 (mm)	구분	1-50	50-100	100-250	250-500	DRAWN	CHECKED	CHECKED	APPROVED
~	√	-	-	-	내경	+0.1	+0.15	+0.25	+0.35	Y.H.J				
▽	√ ^W	100S	25a	100Z	외경	-0.1	-0.15	-0.25	-0.35					
▽	√ ^X	25S	63a	25Z	전장	±0.1	±0.15	±0.25	±0.35					
▽	√ ^Y	6.3S	1.6a	6.3Z	SCALE	1 : 1								
▽	√ ^Z	0.8S	0.2a	0.8Z	Dim.	mm								

SSK
 신세기산업주식회사