

APPROVAL

DATE

SIGNATURE

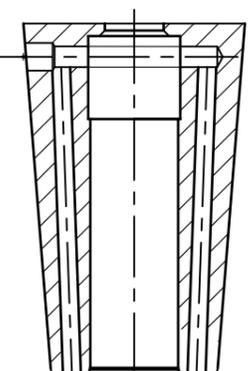

- NOTE
- 1.ROUND R=1.0
 - 2.BREAK SHARP CORNERS 0.5×45°
 - 3.ANGLES ±0°15'
 - 4.SFH-C ADJUST BOLT (T) : M10×1.0×15L
 - 5.NYLOC BOLT : M4×0.7×4L(4EA)
 - 6.BALANCE : G2.5 / 25,000rpm

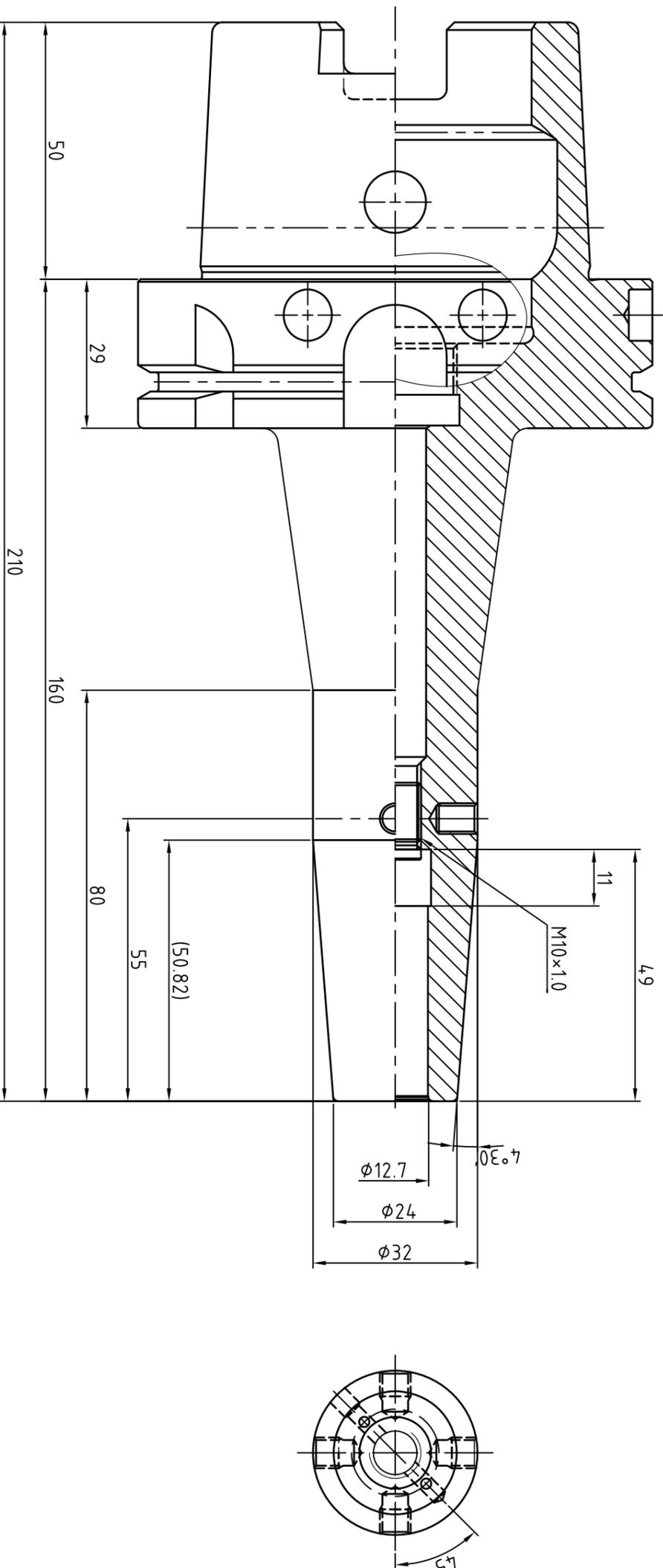

MARKING

HSK100A-SFH1/2CTW-6.30
 VR030JTW 월/년0일 G2.5/25,000

MATERIAL	REV No.	00	DATE	2021.03.22	표	기	호	Rmax	-	Ra	-	Rz	-	기	본	차	구	분	1-50	50-100	100-250	250-500	DRAWN	CHECKED	CHECKED	APPROVED
MAT. SIZE	SURFACE TREATMENT				~	▽	▽							구	분	내	경						Y.H.J			
HARDNESS	KIND	ASME B5.50	: 2009		▽	▽	▽	100S	25a	63a	100Z			구	분	외	경									
DESCRIPTION	SHRINK FIT HOLDER				▽	▽	▽	25S	63a	25Z				구	분	전	장									
ORDER MAKER	SAB	OEM CODE	VR030JTW	TYPE	도	▽	▽	6.3S	1.6a	6.3Z				SCALE	1 : 1	mm										
SPEC.	HSK100A-SFH12.7(1/2")CTW-160(6.3")				도	▽	▽	0.8S	0.2a	0.8Z				Dim.	mm											

SSK
 신세기산업주식회사