

NO.	DATE	REVISION	DRAWN

<b>APPROVAL</b>
DATE
SIGNATURE

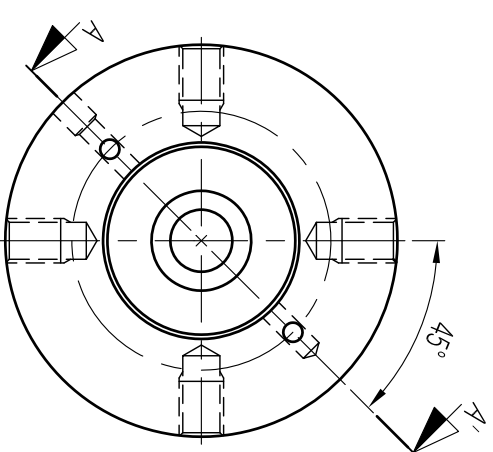
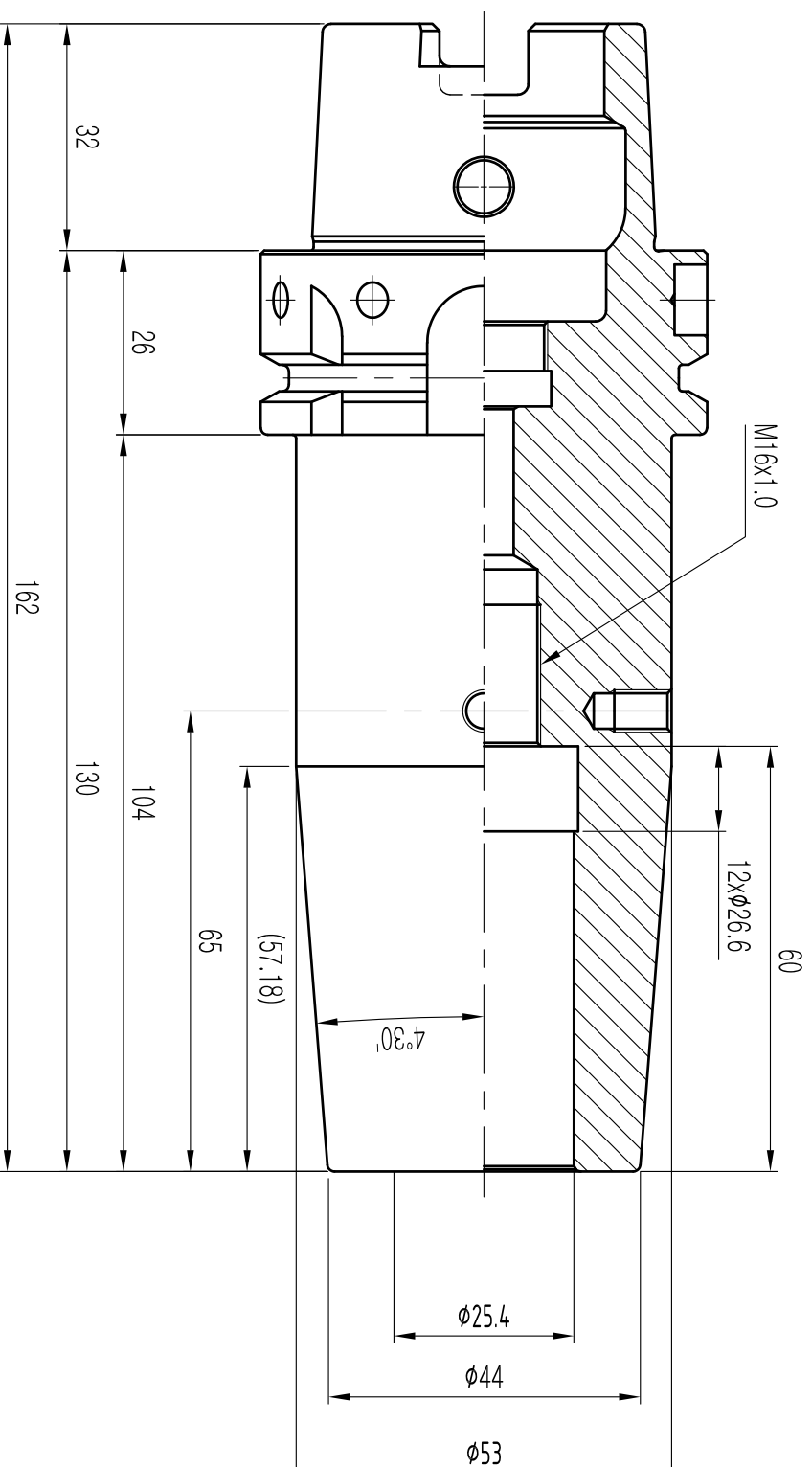
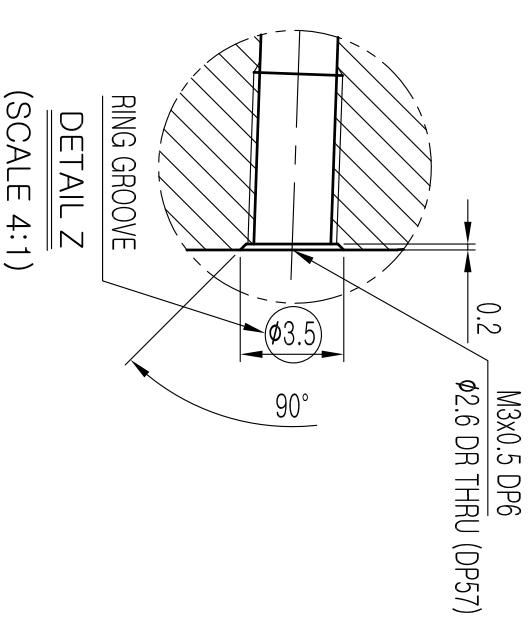
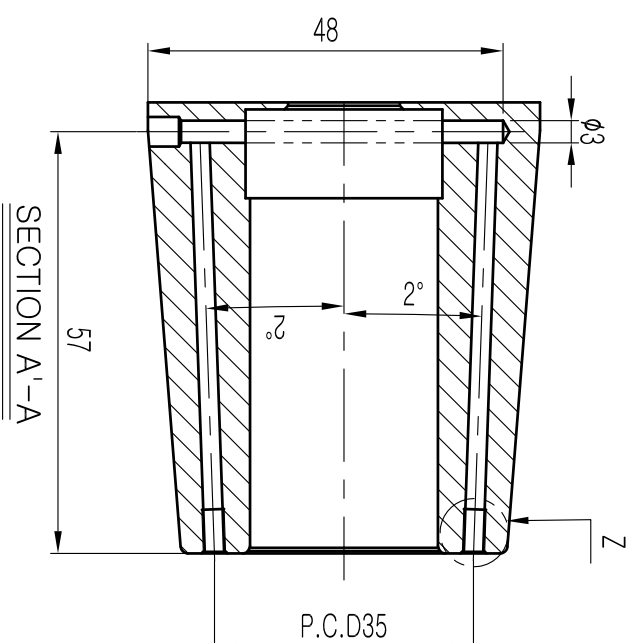

- NOTE**
1. ROUND R=1.0
  2. BREAK SHARP CONERS 0.5X45°
  3. ANGLES ±0°15'
  4. BALANCE : G2.5 / 25,000rpm

**MARKING**

HSK63A-SFH1CR-5.12  
 VQ308JR 월/년0일 G2.5/25,000

MATERIAL	REV No.	00	DATE	2021.03.18	표	기	호	Rmax	Ra	Rz	기	본	구	부	1-50	50-100	100-250	250-500	DRAWN	CHECKED	CHECKED	CHECKED	APPROVED
MAT. SIZE	SURFACE TREATMENT	00	DATE	2021.03.18	~	▽	▽	-	-	-	기	본	구	부	1-50	50-100	100-250	250-500	Y.H.J				
HARDNESS	H <sub>RC</sub>	KIND	ISO12164-1		▽	▽	▽	100S	25a	100Z	차	차	내	외	+0.1	+0.15	+0.25	+0.35					
DESCRIPTION	SHRINK FIT HOLDER				▽	▽	▽	25S	63a	25Z	(mm)	전	장	±0.1	±0.15	±0.25	±0.35						
ORDER MAKER	SAB	OEM CODE	VQ308JR		▽	▽	▽	63S	1.6a	63Z	SCALE	1 : 1											
SPEC.	HSK63A-SFH25.4(1)CR-130(5.12")	TYPE	Machining		▽	▽	▽	0.8S	0.2a	0.8Z	Dim.	mm											

**SSK**  
신세기산업주식회사