

APPROVAL
DATE
SIGNATURE

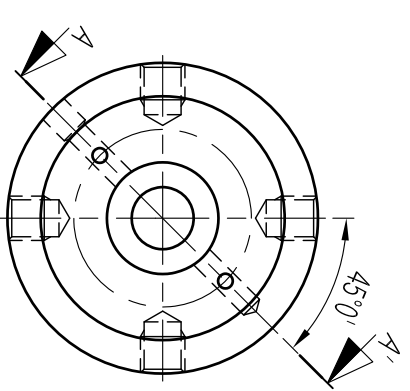
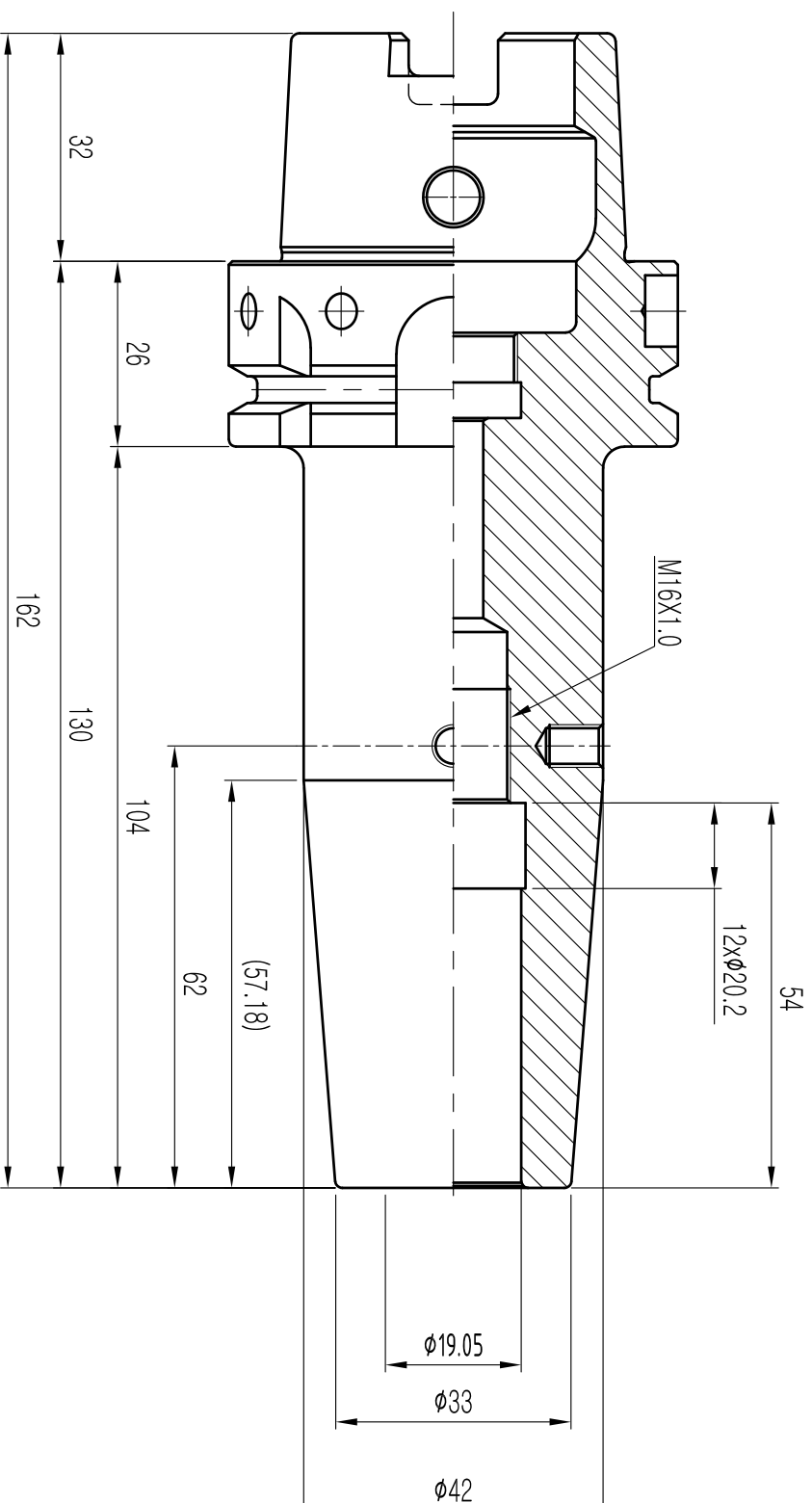
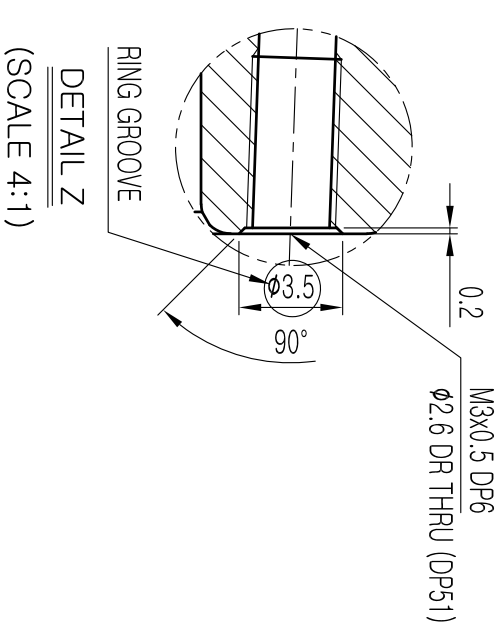
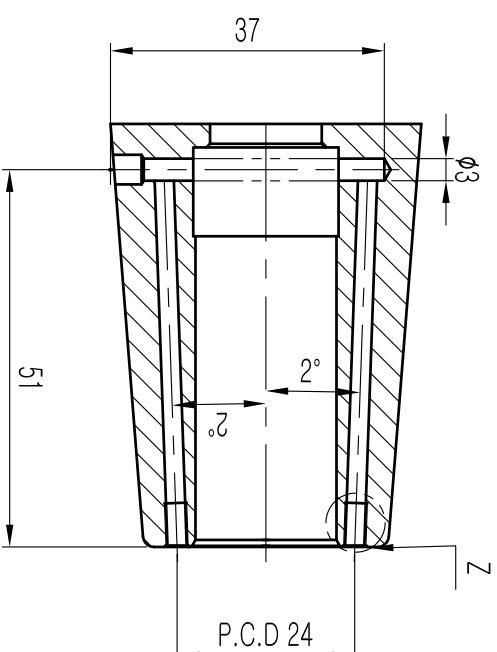

MARKING

HSK63A-SFH3/4CR-5.12
 VQ307JR 월/년0일 G2.5/25,000

- NOTE**
1. ROUND R=1.0
 2. BREAK SHARP CONERS 0.5x45°
 3. ANGLES ±0°15'
 4. BALANCE : G2.5 / 25,000rpm

MATERIAL	REV No.	00	DATE	2021.03.18	기 호	Rmax	Ra	Rz	기 본 차 (mm)	SCALE	1 : 1	DRAWN	CHECKED	CHECKED	APPROVED	
MAT. SIZE	SURFACE TREATMENT				~	-	-	-	구 분	1-50	50-100	100-250	250-500			
HARDNESS	H _{RC}	KIND	ISO12164-1		▽	▽	▽	▽	내 경	+0.1	+0.15	+0.25	+0.35	Y.H.J		
DESCRIPTION	SHRINK FIT HOLDER				▽	▽	▽	▽	외 경	+0	+0.15	+0.25	+0.35			
ORDER MAKER	SAB	OEM CODE	VQ307JR		▽	▽	▽	▽	전 장	±0.1	±0.15	±0.25	±0.35			
SPEC.	HSK63A-SFH19.05(3/4)CR-130(5.12")	TYPE	Machining		▽	▽	▽	▽	Dim.	mm						