

# APPROVAL

DATE

SIGNATURE

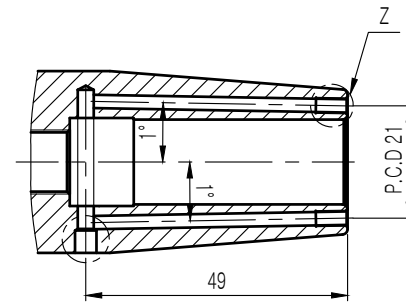

SECTION A-A

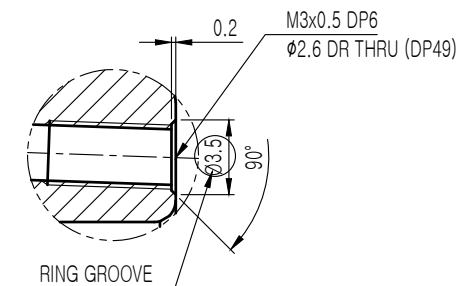

RING GROOVE

DETAIL Z

(SCALE 4:1)

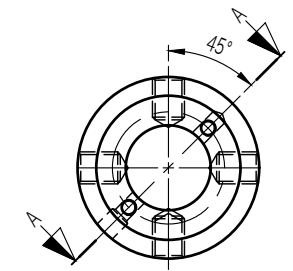
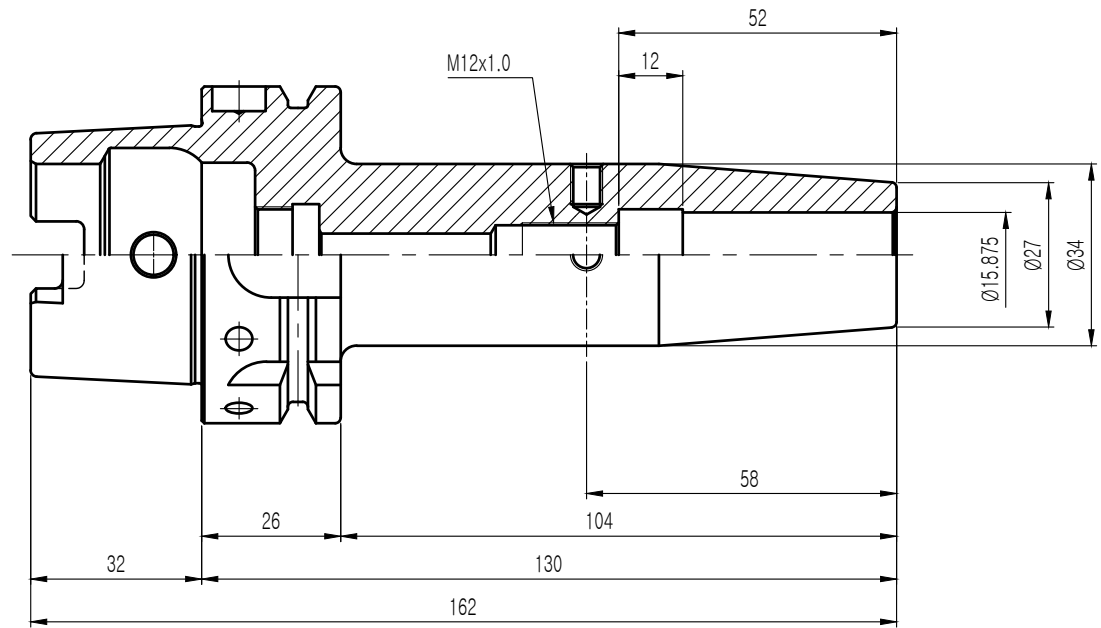

### MARKING

SSK HSK63A-SFH5/8CR-5.12  
VQ306JR 월/년0일 G2.5/25,000

### NOTE

1. ROUND R=1.0
2. BREAK SHARP CONERS 0.5x45°
3. ANGLES ±0°15'
4. BALANCE : G2.5 / 25,000rpm

MATERIAL	REV No.	00	DATE	2023.05.30	표 면 조 도	기 호	Rmax	Ra	Rz	기 구 분 차 이 별 본	구분	1-50	50-100	100-250	250-500	DRAWN	CHECKED	CHECKED	APPROVED	
MAT. SIZE	SURFACE TREATMENT		~			▽	▽	▽	▽		내경	+0.1 -0	+0.15 -0	+0.25 -0	+0.35 -0					
HARDNESS	H <sub>RC</sub>	KIND	ISO12164-1			▽▽	▽▽	▽▽	▽▽		외경	+0 -0.1	+0 -0.15	+0 -0.25	+0 -0.35					
DESCRIPTION	SHRINK FIT HOLDER					▽▽▽	▽▽▽	▽▽▽	▽▽▽		전장	±0.1	±0.15	±0.25	±0.35					
ORDER MAKER	SAB	OEM CODE	VQ306JR			▽▽▽▽	▽▽▽▽	▽▽▽▽	SCALE		1 : 1				SSK 신세기산업주식회사					
SPEC.	HSK63A-SFH15.875(5/8)CR-130(5.12")			TYPE	Machining	▽▽▽▽	▽▽▽▽	▽▽▽▽	Dim.	mm										