

<b>APPROVAL</b>
DATE
SIGNATURE

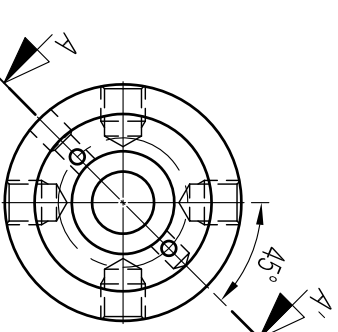
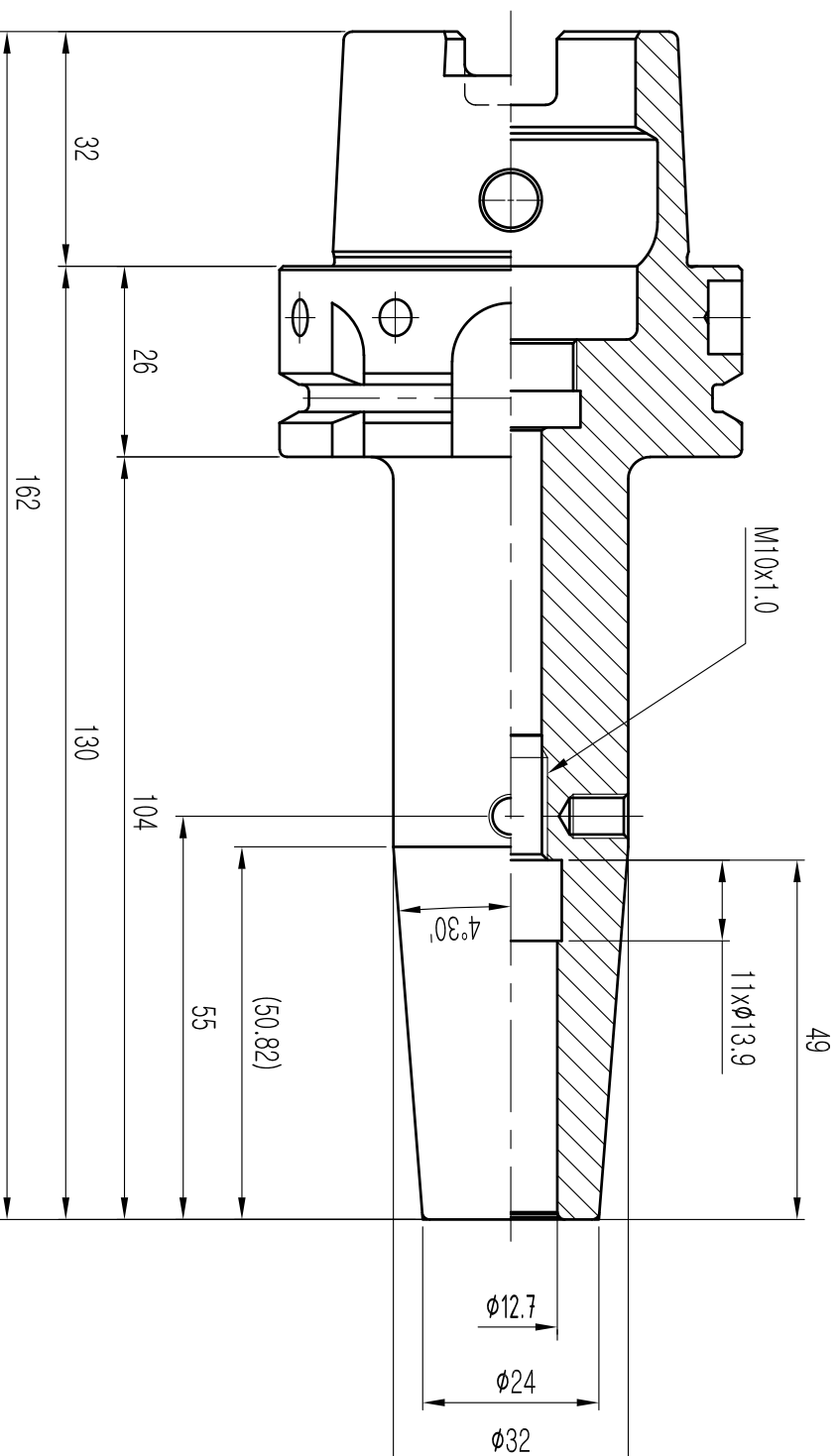
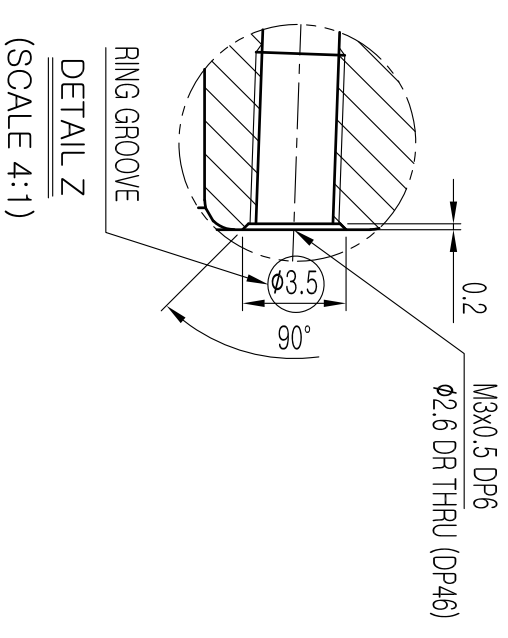
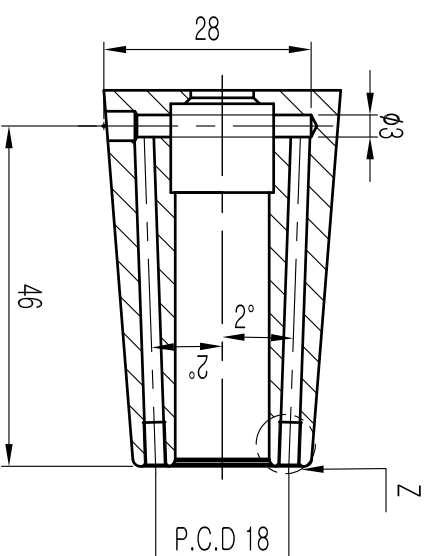

**NOTE**

1. ROUND R=1.0
2. BREAK SHARP CONERS 0.5x45°
3. ANGLES ±0°15'
4. BALANCE : G2.5 / 25,000rpm

**MARKING**

HSK63A-SFH1/2CR-5.12  
 VQ305JR 월/년0일 G2.5/25,000

MATERIAL	REV No.	00	DATE	2021.03.18	표	기	후	Rmax	-	Ra	-	Rz	-	기	본	차	구	분	1-50	50-100	100-250	250-500	DRAWN	CHECKED	CHECKED	CHECKED	APPROVED
MAT. SIZE	SURFACE TREATMENT				면	~	▽							내	경	+0.1	-0	+0.35					Y.H.J				
HARDNESS	H <sub>RC</sub>	KIND	ISO12164-1		조	▽	25	100S	25a	100Z			외	경	+0	-0.15	+0	-0.35									
DESCRIPTION	SHRINK FIT HOLDER				도	▽	63	25S	63a	25Z			전	장	±0.1	±0.15	±0.25	±0.35									
ORDER MAKER	SAB	OEM CODE	VQ305JR			▽	19	63S	1.6a	63Z					±0.25	±0.35											
SPEC.	HSK63A-SFH12.7(1/2)CR-130(5.12")	TYPE	Machining			▽	02	0.8S	0.2a	0.8Z																	