

APPROVAL	
DATE	
SIGNATURE	

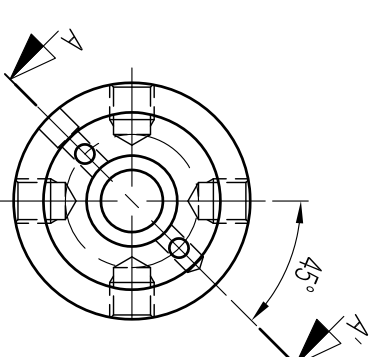
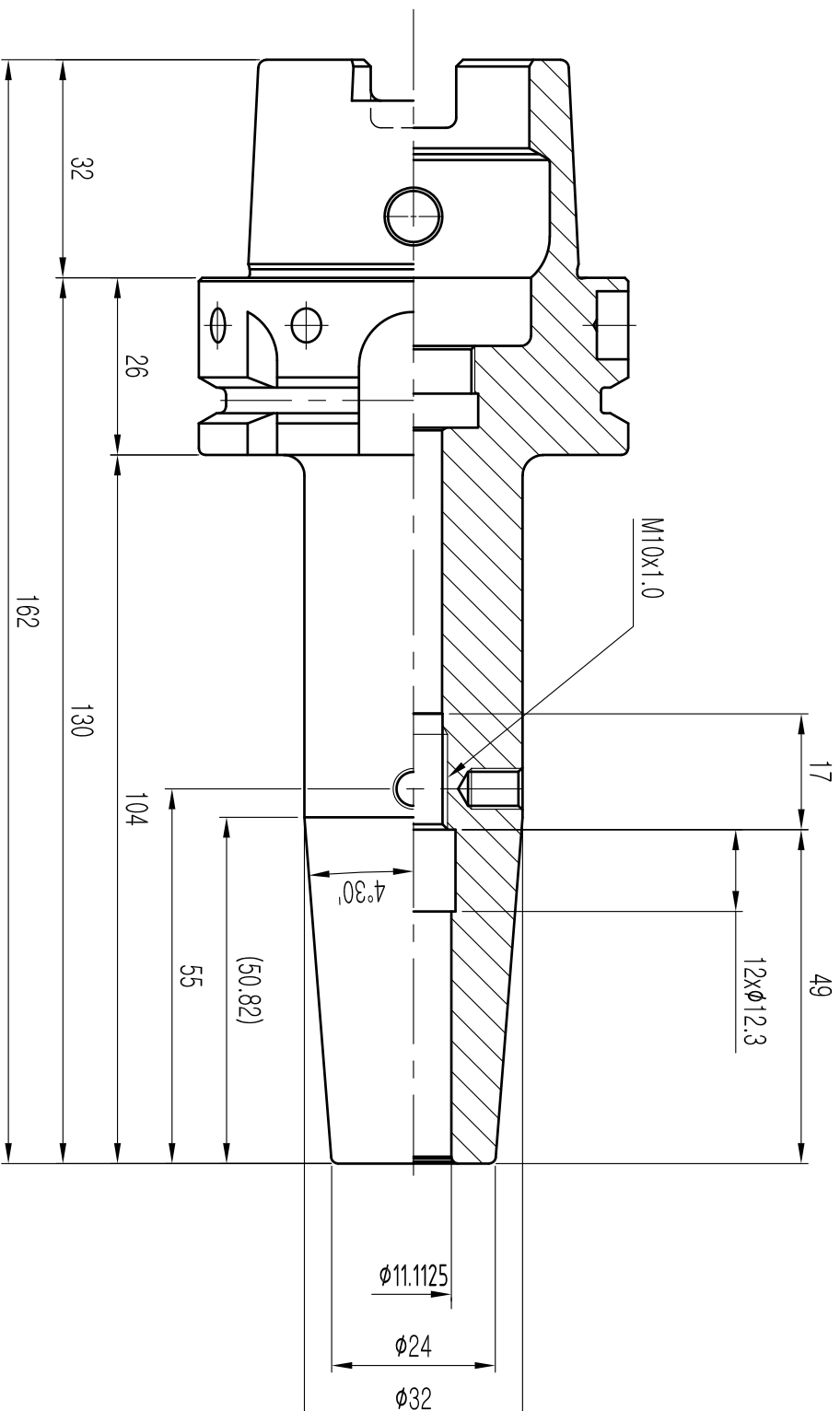
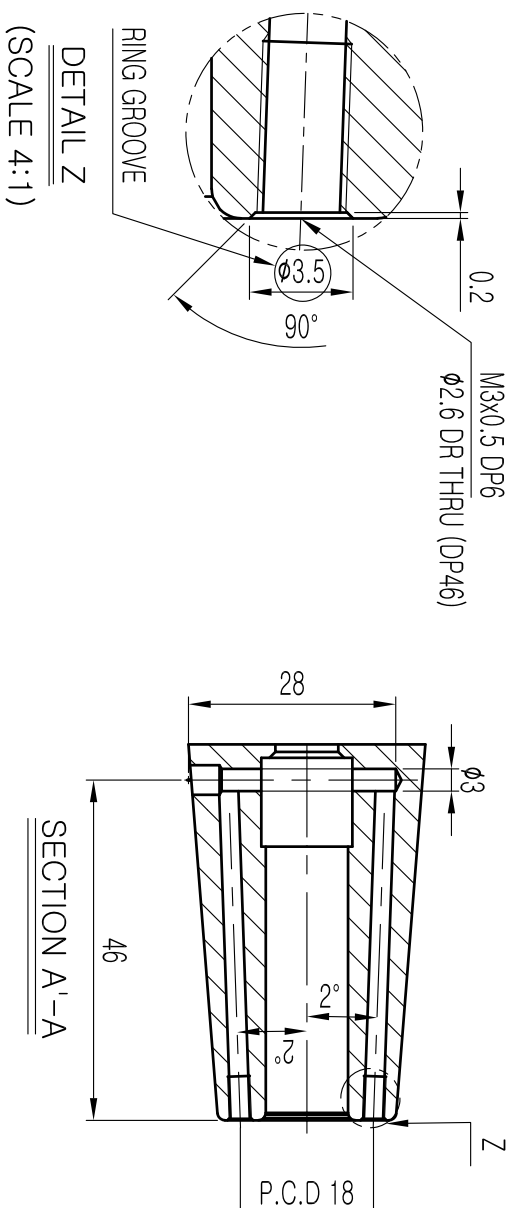

MARKING

SSK HSK63A-SFH7/16CR-5.12
VQ304JR 월/년0일 G2.5/25,000

- NOTE**
1. ROUND R=1.0
 2. BREAK SHARP CONERS 0.5x45°
 3. ANGLES ±0°15'
 4. BALANCE : G2.5 / 25,000rpm

MATERIAL	REV No.	00	DATE	2021.03.18	기 호	Rmax	Ra	Rz	기 본 차 (mm)	SCALE	1 : 1	DRAWN	CHECKED	CHECKED	APPROVED	
MAT. SIZE	SURFACE TREATMENT				~	-	-	-	구분	1-50	50-100	100-250	250-500			
HARDNESS	KIND	H _{RC}	ISO12164-1		▽	100S	25a	100Z	내경	+0.1	-0.15	-0.25	+0.35			
DESCRIPTION	SHRINK FIT HOLDER				▽	25S	63a	25Z	외경	+0	-0.15	-0.25	+0			
ORDER MAKER	SAB				▽	63S	1.6a	63Z	전장	±0.1	±0.15	±0.25	±0.35			
SPEC.	HSK63A-SFH11.1125(7/16"CR-130(5.12"))	OEM CODE	VQ304JR	TYPE	▽	0.8S	0.2a	0.8Z	SCALE	1 : 1						
					▽	0.85	0.2a	0.8Z	Dim.	mm						

SSK
신세기산업주식회사