

NO.	DATE	REVISION	DRAWN

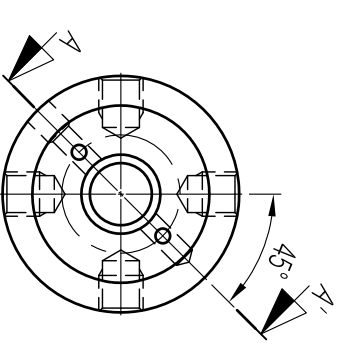
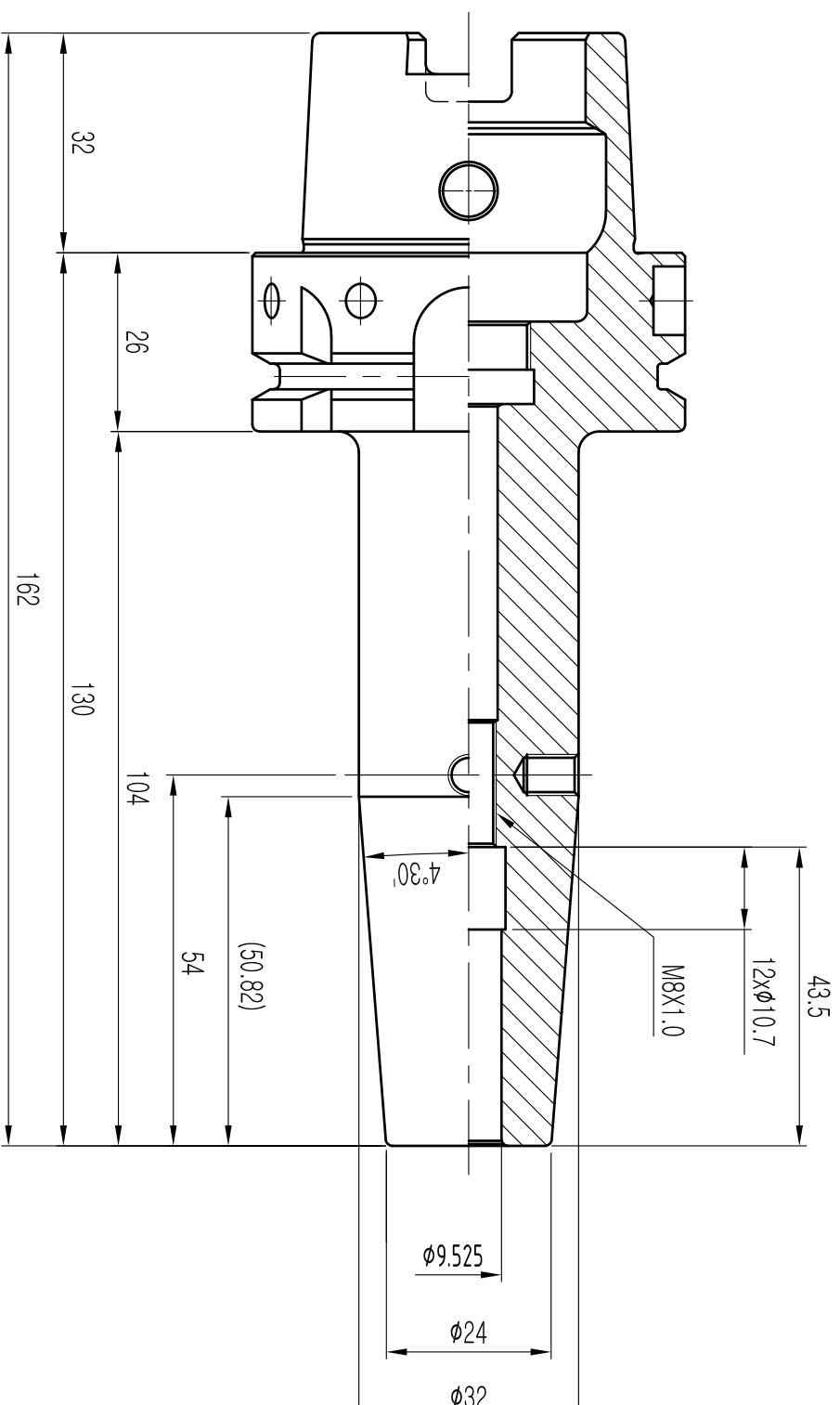
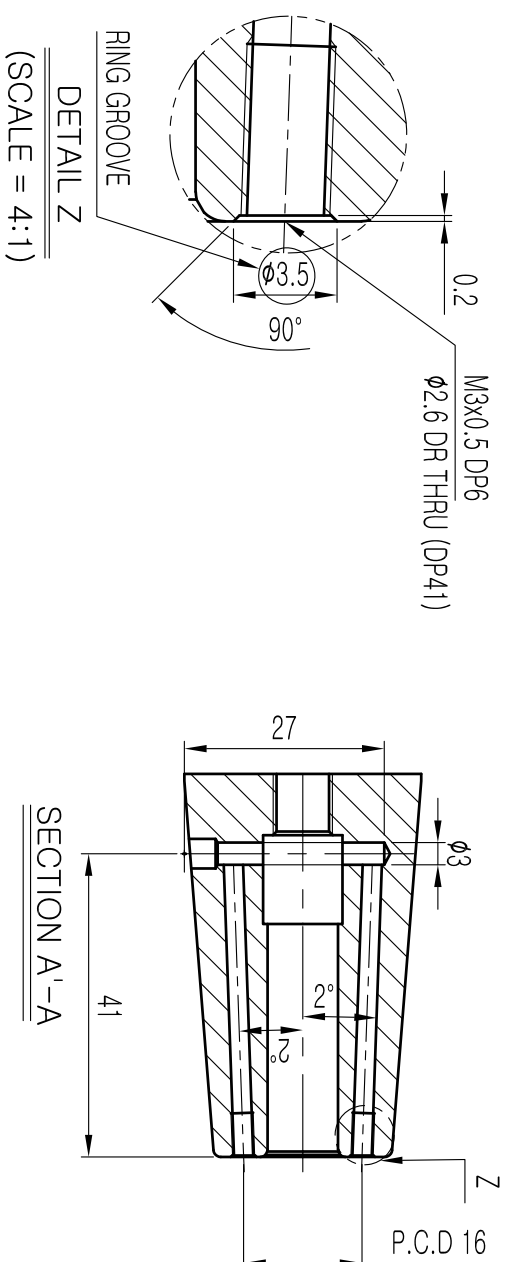

- NOTE**
1. ROUND R=1.0
 2. BREAK SHARP CONERS 0.5x45°
 3. ANGLES ±0°15'
 4. BALANCE : G2.5 / 25,000rpm

MARKING
 HSK63A-SFH3/8CR-5.12
 VQ303JR 월/년0일 G2.5/25,000

APPROVAL
 DATE
 SIGNATURE

MATERIAL	REV No.	00	DATE	2021.03.18	기 호	Rmax	Ra	Rz	기 본 차 (mm)	SCALE	1 : 1	Dim.	mm
MAT. SIZE	SURFACE TREATMENT				~	-	-	-	구분	1-50	50-100	100-250	250-500
HARDNESS	KIND	H _{RC}	ISO12164-1		▽	100S	25a	100Z	내경	+0.1	-0.15	-0.25	+0.35
DESCRIPTION	SHRINK FIT HOLDER				▽	25S	63a	25Z	외경	+0	-0.15	-0.25	+0
ORDER MAKER	SAB				▽	63S	1.6a	63Z	전장	±0.1	±0.15	±0.25	±0.35
SPEC.	HSK63A-SFH9.525CR(3/8)-130(5.12")	OEM CODE	VQ303JR	TYPE	Machining	0.85	0.2a	0.8Z	SCALE	1 : 1			

SSK
 신세기산업주식회사