

<b>APPROVAL</b>
DATE
SIGNATURE

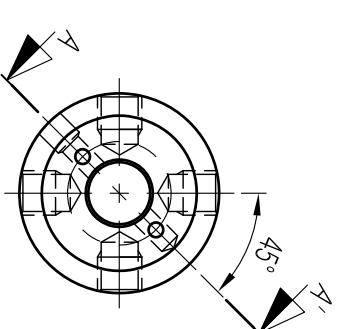
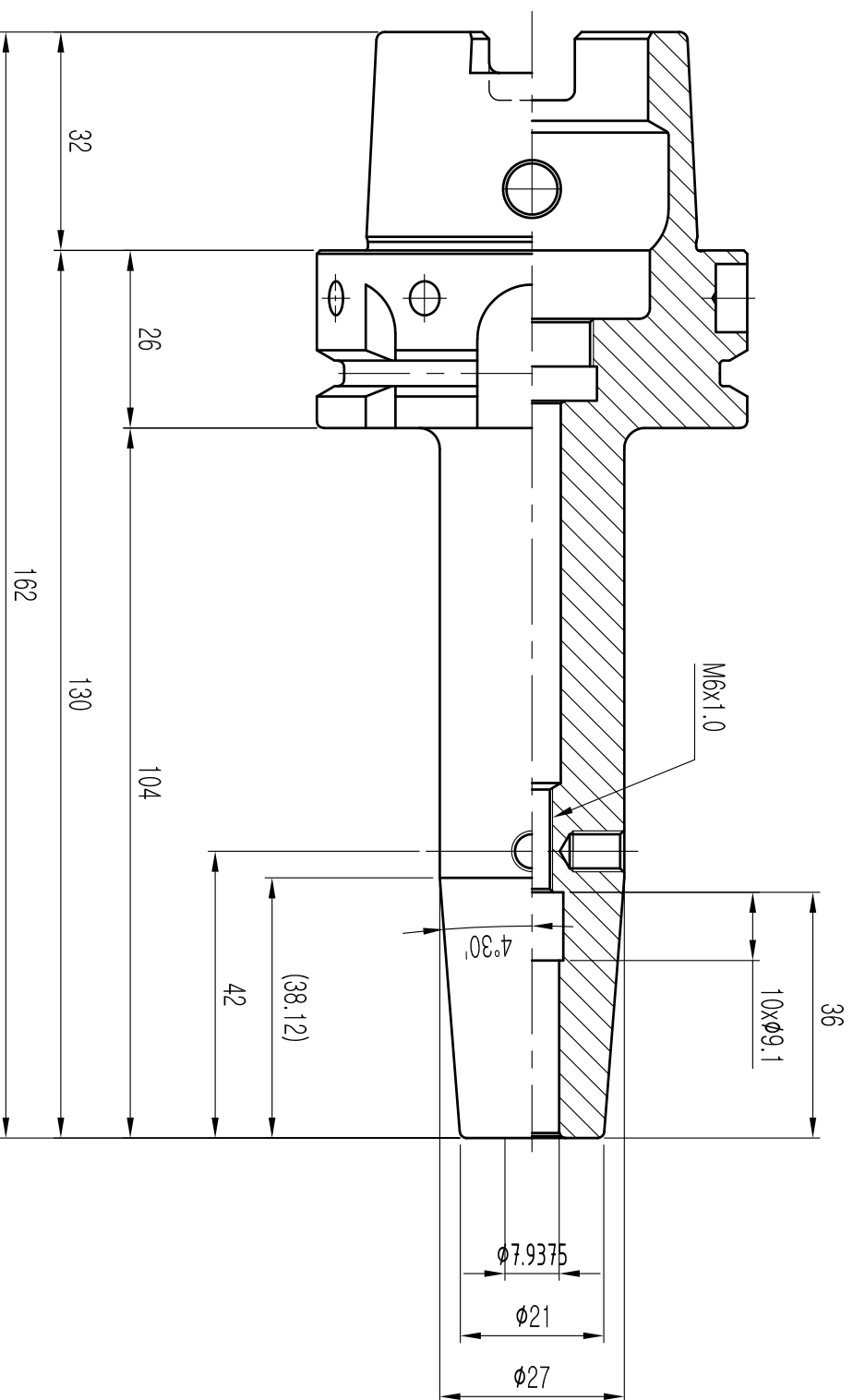
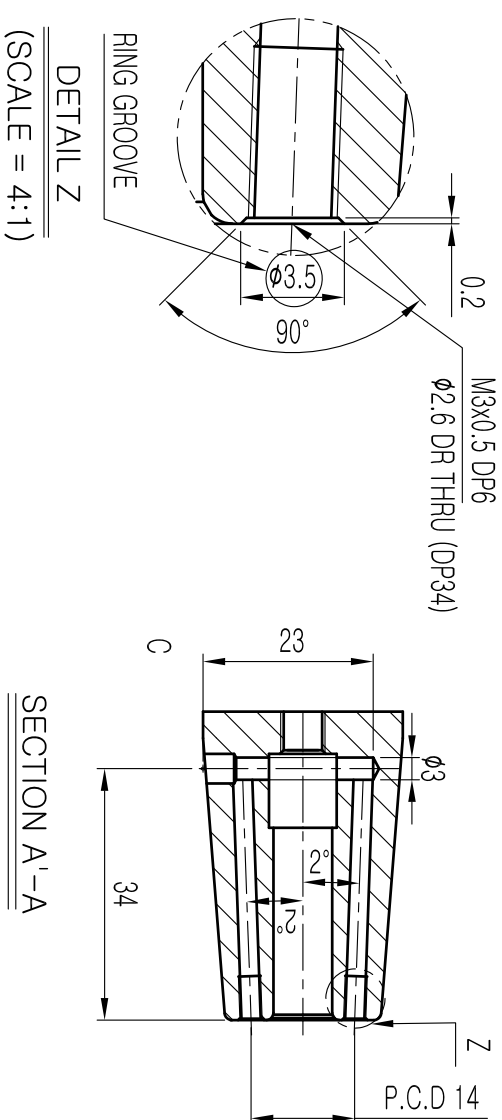

- NOTE**
1. ROUND R=1.0
  2. BREAK SHARP CONERS 0.5x45°
  3. ANGLES ±0°15'
  4. BALANCE : G2.5 / 25,000rpm

**MARKING**

SSK HSK63A-SFH5/16CR-5.12  
VQ302JR 월/년0월 G2.5/25.000

MATERIAL	REV No.	00	DATE	2021.03.18	기 호	Rmax	Ra	Rz	기 본 차 (mm)	SCALE	1 : 1	DRAWN	CHECKED	CHECKED	APPROVED
MAT. SIZE	SURFACE TREATMENT				~	-	-	-	구 분			Y.H.J			
HARDNESS	KIND	ISO12164-1			▽	100S	25a	100Z	내 경						
DESCRIPTION	SHRINK FIT HOLDER				▽	25S	63a	25Z	외 경						
ORDER MAKER	SAB	OEM CODE	VQ302JR		▽	63S	1.6a	63Z	전 장						
SPEC.	HSK63A-SFH7.9375(5/16)"CR-130(5.12")	TYPE	Machining		▽	0.85	0.2a	0.8Z	SCALE						