

APPROVAL	
DATE	
SIGNATURE	

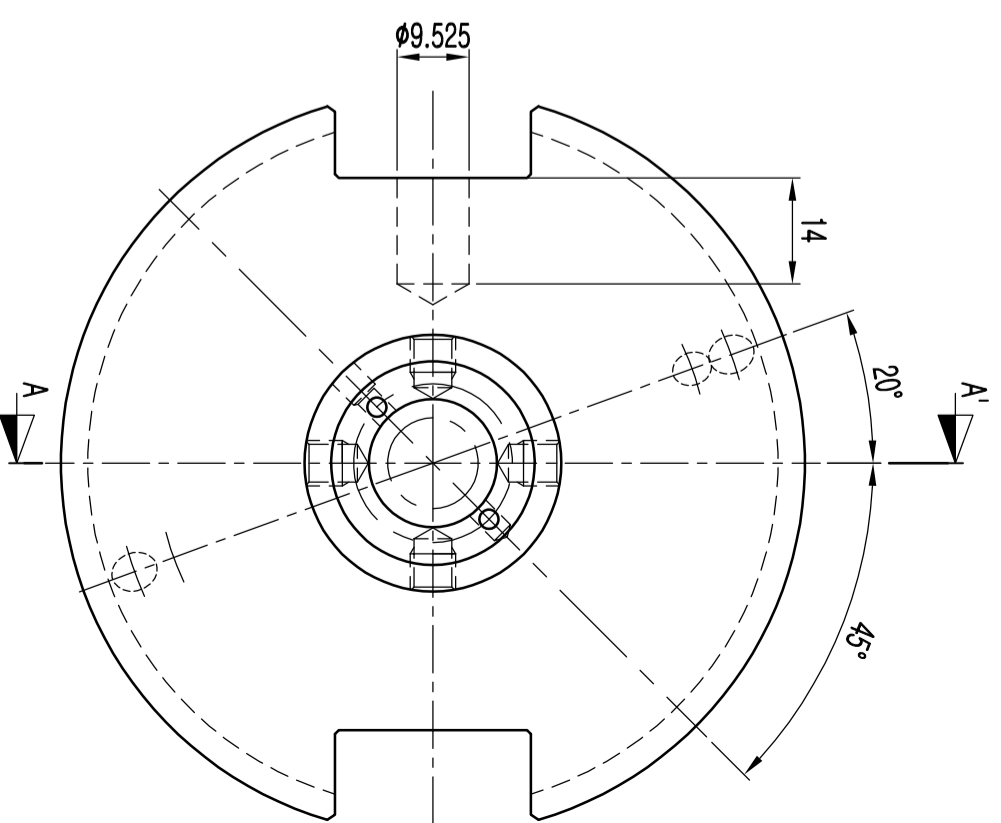
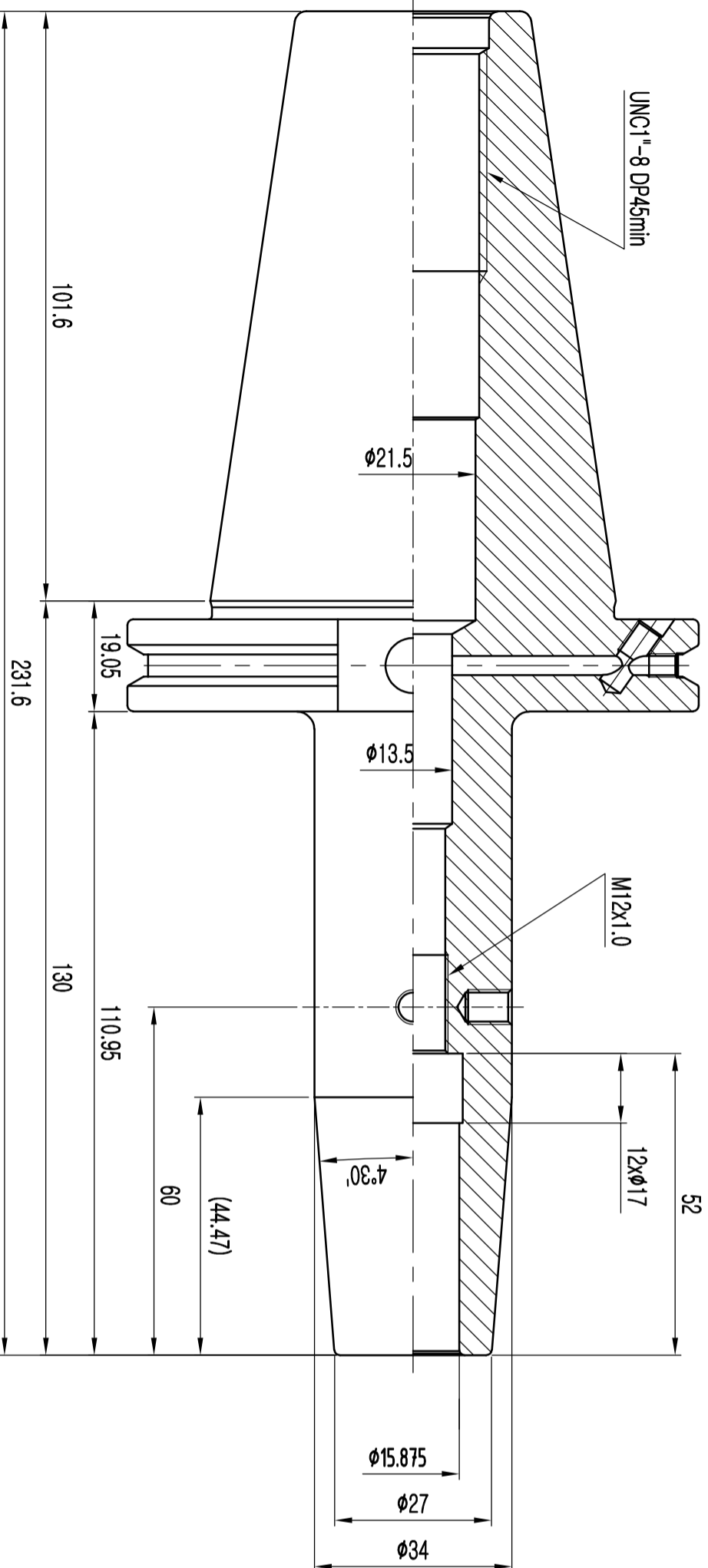
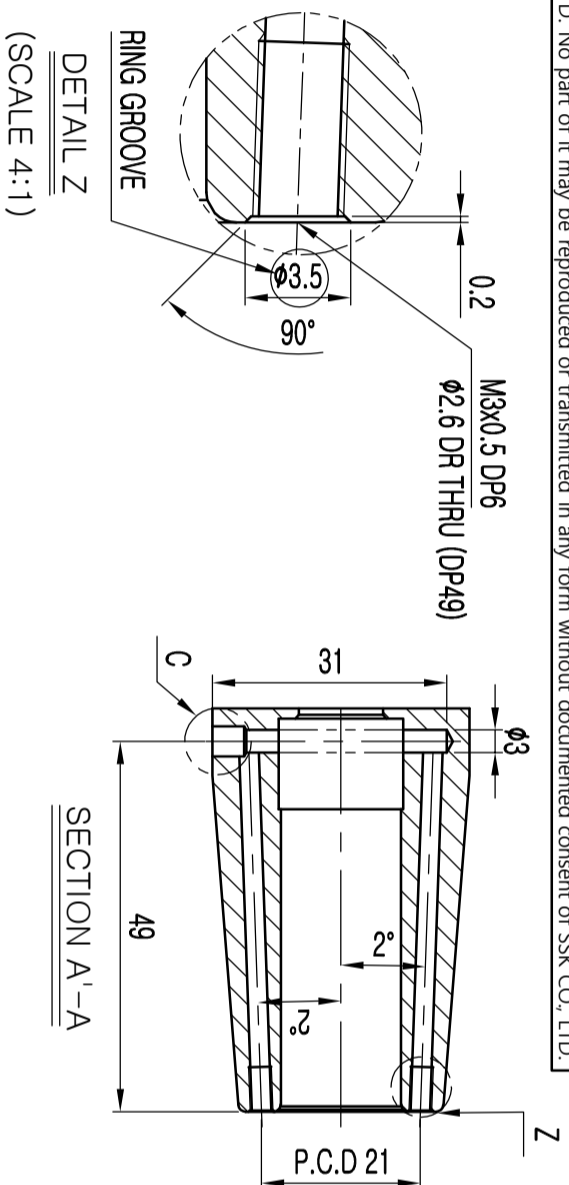

MARKING	
CAT50AD/B-SFH5/8CR-5.12 VL205JR 월/년0일 G2.5/25,000	

MATERIAL		REV No.	00	DATE	2021.03.17
MAT. SIZE		SURFACE TREATMENT			
HARDNESS	HrC	KIND	ASM E B5.50 : 2009		
DESCRIPTION	SHRINK FIT HOLDER				
ORDER MAKER	SAB	OEM CODE	VL205JR	TYPE	Machining
SPEC.	CAT50AD/B-SFH15.875(5/8")CR-130(5.12")				

기호	Rmax	Ra	Rz	기본문자	SCALE	Dim.
~	-	-	-		1 : 1	mm
▽	100S	25a	100Z	내경	±0.1	±0.15
▽▽	25S	63a	25Z	외경	±0.1	±0.15
▽▽▽	6.3S	1.6a	6.3Z	전장	±0.1	±0.15
▽▽▽▽	0.8S	0.2a	0.8Z			

DRAWN	CHECKED	CHECKED	CHECKED	APPROVED
Y.H.J				
SSK 신세기산업주식회사				