

APPROVAL

DATE

SIGNATURE

NOTE

- 1.ROUND R=1.0
- 2.BREAK SHARP CORNERS 0.5×4.5°
- 3.ANGLES ±0°15'
- 4.SFH-C ADJUST BOLT (T) : M10×1.0×15L
- 5.NYLOC BOLT : M4×0.7×4L(4EA)
- 6.BALANCE : G2.5 / 25,000rpm

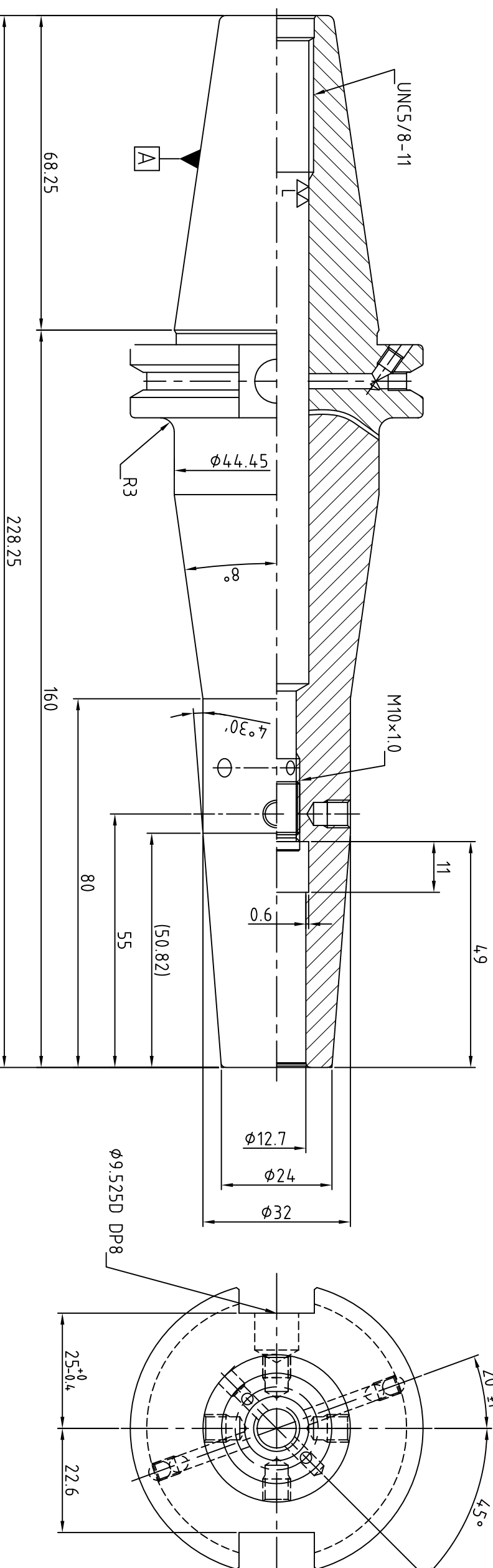
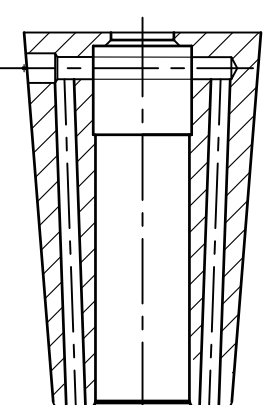

MATERIAL	REV No.	00	DATE	2021.03.19
MAT. SIZE	SURFACE TREATMENT			
HARDNESS	H _R C	KIND	ASME B5.50 : 2009	
DESCRIPTION	SHRINK FIT HOLDER			
ORDER MAKER	SAB	OEM CODE	VK034JTW	
SPEC.	CAT40AD/B-SFH12.7(1/2")CTW-160(6.3")			
			TYPE	Machining

표면	기호	Rmax	Ra	Rz	기분공차 (mm)	구분	내경	외경	전장
~	▽	-	-	-	1-50	+0.1	-0.1	+0.1	±0.1
▽	▽ ^W	100S	25a	100Z	50-100	+0.15	-0.15	+0.15	±0.15
▽	▽ ^X	25S	63a	25Z	100-250	+0.25	-0.25	+0.25	±0.25
▽	▽ ^Y	6.3S	1.6a	6.3Z	250-500	+0.35	-0.35	+0.35	±0.35
▽	▽ ^Z	0.8S	0.2a	0.8Z					

SCALE	1 : 1
Dim.	mm

DRAWN	CHECKED	CHECKED	CHECKED	APPROVED
Y.H.J				

SSK
 신세기산업주식회사
 A3 (420x297)